

**Amendments to the Statewide Urban Design and Specifications (SUDAS)
Design Standards Manual and Specifications Manual by the City of Tiffin**
Approved Date: April 4, 2017

Introduction

There are references made throughout this document to the “City Engineer”. The “City Engineer” is also referred to as the Jurisdictional Engineer throughout the SUDAS Manuals and this document. This is the engineer employed by the community; public official or engineering consultant retained by the community that functions as the local engineering authority.

The SUDAS Design Standards Manual and the SUDAS Specifications Manual have been modified by the amendments contained in this document to meet the needs of the City of Tiffin. The City of Tiffin reserves the right to periodically review and update these amendments to the SUDAS Design Standards Manual and the Specifications Manual. Contact the City of Tiffin to validate these amendments before their use.

When it becomes necessary or desirable to vary from the standards and amendments presented in this document, a variance may be requested by the Project Engineer to the City of Tiffin. Such a request shall be made in writing and will include:

1. The standard to be varied.
2. The proposed variation.
3. Justification for the variance.

A written response will be given within thirty (30) business days of the request.

Additional amendments to these standards may be requested by writing to the City of Tiffin with details and justification for an amendment. The City Engineer will meet periodically to discuss proposed amendments and make recommendations to the Planning and Zoning Commission and City Council.

Questions regarding these design standards should be directed to:

The City of Tiffin, City Administrator/Clerk
300 Railroad Street, P.O. Box 259
Tiffin, IA 52340
Tel: (319) 545-2572
Fax: (319) 545-4147

The SUDAS Design Standards Manual may be viewed and printed online at
<http://www.iowasudas.org/manuals/manual.cfm?manual=design>

The SUDAS Standard Specifications Manual may be viewed and printed online at
<http://www.iowasudas.org/manuals/manual.cfm?manual=specifications>

The Statewide Urban Design and Specifications (SUDAS) Design Standards Manual shall be adopted with the following amendments:

Chapter 1: General Provisions

1A-1 B Add the following statement at the end of the second paragraph:

The SUDAS Design Manual shall apply to replacement, maintenance, restoration, and rehabilitation projects to the fullest extent feasible.

1B-1 A. Add the following statement:

Jurisdictional Engineer shall also be known as the City Engineer as appointed by the Tiffin City Council.

1B-1 C. Add the following statement:

The Jurisdiction may assign 'City Staff' to perform some or all of the duties of the inspector.

1B-1 D. Substitute Building Permit for 'plumbing permit'.

1B-1 E. Substitute Building Permit for 'plumbing permit'.

1B-1 F. Add the following paragraph:

All gravity mains shall be a minimum of 8-inches in diameter. Developers will be responsible for installing pipe sizes up to 15-inches in diameter within or outside of the development. Consideration for reimbursement of the increase in material costs for mains larger than 15-inches, required for the future needs of the City, may be approved by Council Action.

1B-1 H. Substitute Building Permit for 'plumbing permit'.

1B-1 I. Substitute Building Permit for 'plumbing permit'.

1B-1 J. Add the following paragraph:

All mains shall be a minimum of 8-inches in diameter. Developers will be responsible for installing pipe sizes up to 12-inches in diameter. Consideration for reimbursement of the increase in material costs for mains larger than 12-inches, required for the future needs of the City, may be approved by Council Action.

1B-1 K. Substitute Building Permit for 'plumbing permit'.

1B-1 L. Substitute Building Permit for 'plumbing permit'.

1B-1S "Jurisdictional Permit" permit shall mean Building Permit except as required by the Iowa Department of Transportation.

1B-1 R. Replace the last sentence of the first paragraph with the following:

Refer to City of Tiffin Ordinance 2012-313 for maintenance responsibilities.

1C-1 D. 6. Add the following statement:

The duration of the maintenance bond is three (3) years for all projects involving public improvements.

1C-1 D. 11. Add the following paragraph:

As-built documentation shall be required in the form of reproducible mylar or vellum and in AutoCAD based digital format on compact disc. Drawings shall include horizontal and vertical locations of sewer services, hydrants, valves, fittings, and water services with ties to the property pins as well as any modifications to the plans made during construction.

1D-1 A. 3. Add the following paragraph:

Copies of the plans submitted by the Project Engineer to the City for review by the Jurisdictional Engineer shall be full-size (24" X 36"). The minimum full-size sheet dimensions are 22"X34". Copies of plans for bidding may be scalable half-size (11"X17).

1D-1 E. 2. Replace the second sentence with the following:

The profile should show centerline and form grade/top-of-slab tangent grades, vertical curve data, and break grade data. Top-of-curb tangent grades may be used with approval of the Jurisdictional Engineer, and when used shall be noted as such.

Chapter 2 Stormwater

2C-3 G. 7. Add the following section:

7. Other Jurisdictional Requirements

Castings shall be non-rocking, self-sealing and meet SUDAS specifications. The words "STORM SEWER" shall be cast into the lid. Chimney seals are not required for storm sewer. Concrete spacers or metal shims shall be the only materials utilized to adjust frame elevations. Grout must be used to bond and seal frames to adjusting spacers.

All manholes shall be marked with two metal fence posts to remain in place until landscaping is complete. In developments, the posts shall remain in place until landscaping has been completed by the lot owner.

2D-1 B. 2 Add the following subparagraphs:

d. Drainage way easements for overland flow shall be of sufficient width to contain the 100-year flow and as a minimum shall include the bottom width and side slopes of the drainage way and any necessary overbank areas.

2D-1 D. 3. a. Change to read "12-inches in diameter."

2D-1 D. 4. c. Add the following statement:

Where velocities in a pipe greater than 15 feet per second are calculated, special provisions shall be made to protect against displacement, abrasion, or shock.

2D-1 D. 7. a. Add the following sub-paragraphs.

1. The maximum slope for storm sewer outlet lines shall be 10%.

2. If reinforced concrete pipe is utilized for outlet lines having a slope greater than or equal to 8%, all joints must be tied together. The flared end section and the last two pipe joints shall be tied together in all instances.

2D-1 D. 10. Add the following:

10. Permitted Flows:

a. No sanitary sewers, sanitary sewer services, or septic tanks shall be discharged into storm sewers.

b. No flows from commercial car washes shall be discharged into storm sewers.

c. Sump pump discharge of ground and surface water is permitted.

d. Only ground water is permitted in sump pump discharge tiles less than 12-inches in diameter. No surface water or roof drains are permitted in these systems.

2D-1 D. 11 Add the Following:

11 Outlets: All pipe outlets must extend to an existing, established drainage channel. If there are no existing channels within the property being developed, the developer shall convey the stormwater through an underground piping system to the nearest established drainage channel.

2D-1 D. 12 Add the following:

12. Subsurface Drainage:

a. In predominantly wet areas, area containing hydric soils, and other such areas designated by the City Engineer, a subsurface drainage system shall be provided to receive discharge from sump pumps.

b. A 2-inch service connection manufacture specifically for the pipe being used and approved by the City Engineer shall be provided for each lot abutting the subsurface drainage system.

c. The end of all sump pump services shall be marked with a metal post or #4 rebar at least 24-inches in length buried vertically to within 1-foot of the finished grade.

2D-1 D. 13 Add the following

13. Other jurisdictional Requirements:

a. No Corrugated PVC pipe shall be installed within the public right-of-way or with easements shared with other utilities except for subsurface drainage pipes.

b. No corrugated PVC pipe shall be used where the pipe crosses easements used by other utilities.

c. Flared end sections are required at all storm sewer outlets and shall include IDOT RF-14 ties and rip-rap or other channel protection as recommended by the City Engineer

2G-1 F. 5. Add the following subsection:

5. Other Jurisdictional Requirements:

Refer to City of Tiffin Ordinance 2012-313 for specific requirements.

a. Dry Hydrant Installation

1.) All wet-bottom detention facilities shall have an emergency vehicle accessible dry hydrant installed. Additional information regarding installation is available at the Office of the City Engineer. All dry hydrants installation sites will be approved by the Fire Chief and construction drawings will be approved by the Fire chief and City Engineer.

2.) Figures G-1.02 and 2G-1.03 show typical installation details.

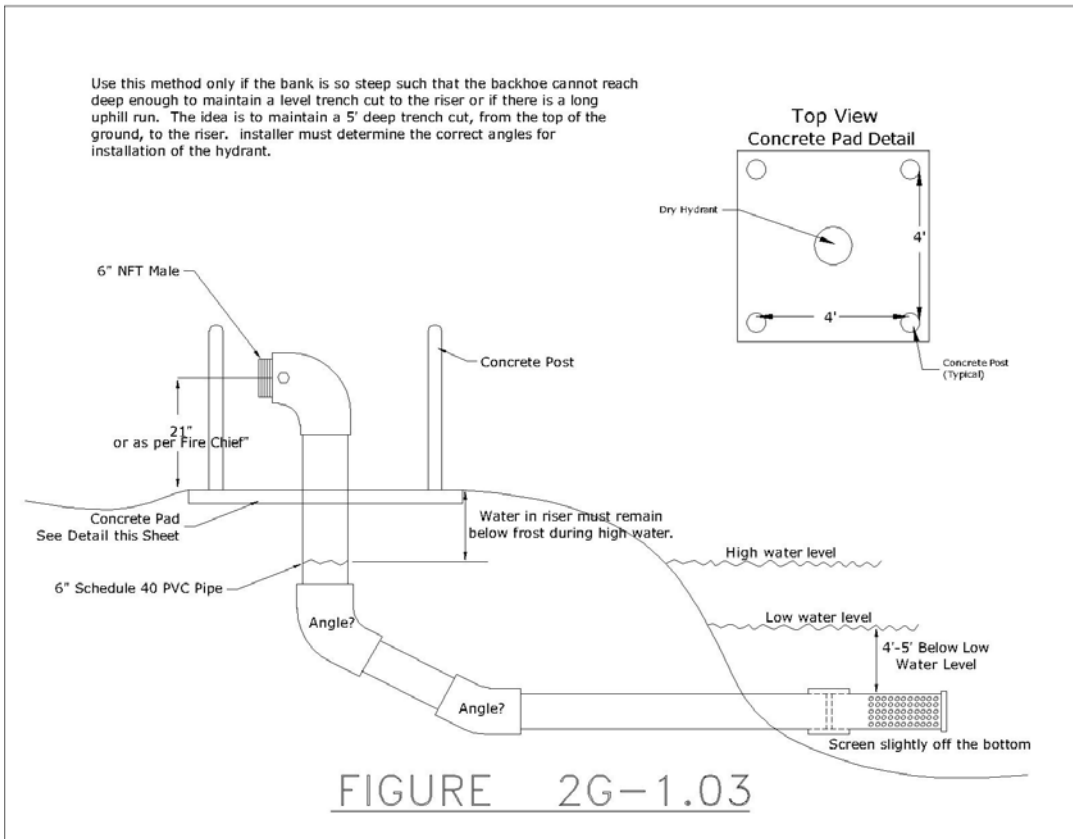
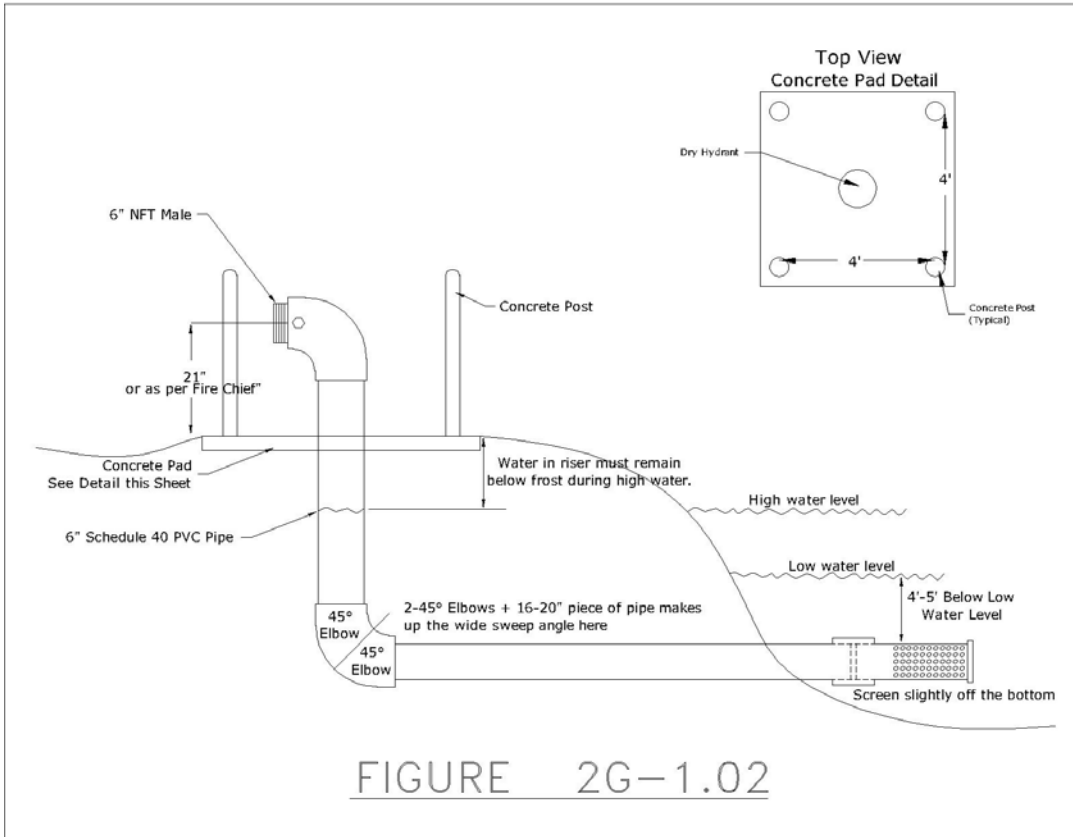

Chapter 3 Sanitary Sewers

3C-1 C Add the following statement:

Solvent welded connections are not acceptable within the right of way or easements.

3C-1 G. 3. Add the following paragraphs:

Sanitary sewers crossing creeks shall be Class 350 Ductile Iron Pipe encased in reinforced concrete or 3/8-inch steel carrier pipe. Encasement shall be no less than 1-foot beneath the natural bottom of the creek. Greater depths may be required by the City Engineer. Rip-rap all disturbed creek banks and bottom after construction.

3C-1 I. 2 .a. Change minimum easement width to read “15-feet”

3C-1 L. 4. a. 4. Replace paragraph with the following:

4. at intervals not exceeding 400-feet.

3C-1 L. 10. Add the following paragraph f.:

f. For manholes with internal drop connections, the manhole diameter shall be 1-foot larger than that calculated in this section.

3C-1 L. Add the following as Article 11.

11. Other Jurisdictional Requirements

Castings shall be non-rocking, self-sealing and meet SUDAS specifications. The words “SANITARY SEWER” shall be cast into the lid. Chimney seals are required for sanitary sewer and shall span from the casting to the cone section. Concrete spacers or metal shims shall be the only materials utilized to adjust frame elevations. Grout must be used to bond and seal frames to adjusting spacers.

All manholes shall be marked with two metal fence posts to remain in place until landscaping is complete. In developments, the posts shall remain in place until landscaping has been completed by the lot owner.

3C-1 M. 2. Add the following as the second sentence and Table 3C-1.04

All sanitary sewers services shall be in accordance with Table 3C-1.04.

**Table 3C-1.04
SEWER SERVICE CONNECTIONS**

| Type | Number of Connections and Size of Service Pipe | Service Requirements |
|-----------------------------------------|-----------------------------------------------------------------------------------------------|------------------------------------------------------------------------------------------------------------------------------|
| SINGLE FAMILY | 1 – 4” | Existing Service Connection of Correct Size or Closest Pipe |
| DUPLEX OR ZERO- LOT LINE | 1 – 6” or 2 – 4” | Existing Service Connection of Correct Size |
| TOWNHOUSE OR MULTIPLE SIDE BY-SIDE APTS | 1 – 6” Service for Each 2 Units or 1 – 4” Service Per Unit ** | Existing Correct Size or Closest Service Connection of Pipe |
| MULTI-STORY APARTMENTS MAX. 6 UNITS | 1 – 6” Service (Max. 6 Units) or 1 – 4” Service for each 2 units ** | All units must be plumbed for Correct Size or Closest Pipe |
| MULTI-STORY APARTMENTS 7 UNITS OR MORE | 1 – 8” Service (Max. 12 Units) or 1 – 6” Service per 6 Units or 1 – 4” Service per 2 Units ** | Existing Service Connection of Correct Size or Closest Pipe. May require larger private service line built to City Standards |
| COMMERCIAL OR MIXED USE DEVELOPMENT | Requires City Engineer Approval. ** Must be sized per IDNR regulations | All units must be plumbed. May require larger private Service line built to City standards |

** Alternate service configurations with design calculations may be submitted to the City Engineer for approval.

3C-1 M. 2. Add the following to the end of the second paragraph:

Internal drops for service connections may be permitted on manhole deeper than 12-feet upon approval of the City Engineer. Internal drops shall be construction SDR 23.5 PVC with stainless steel bands and fasteners spaced at a maximum of 4-feet. A minimum of two (2) attachment point is required.

3C-1 M Add the following as articles 6, 7, and 8:

6. Sanitary service stubs will be extended from the main to the right-of-way line or outer sewer utility easement line, whichever is further.

7. No two sanitary services shall be constructed in the same trench. Service connections shall be separated by a minimum of 6-feet.

8. The end of all sanitary service stubs shall be marked with a metal post, #4 rebar at least 24-inches in length buried vertically within 1-foot of the finished grade, or a painted 4-inch by 4-inch wood post.

3C-1 N Add the following as Article 3:

3.Lift Stations

It is the City’s intention and preference to have all extensions or additions to the sanitary sewer collection system be gravity sewer systems. If gravity sewer is not feasible, lift stations shall be designed to have regional service areas, telemetric alarm systems, provisions for the connection of standby power and auxiliary pumping.

3D-1 Add the following items to Table 3D-1.01

| Typical Application | Pipe Material | Size Range | Standard | Thickness Class (min.) | Pipe Stiffness (min.) | Joints |
|---------------------|---------------|------------|-------------|------------------------|-----------------------|-----------------|
| Sanitary Service | PVC | 4" and 6" | ASTM D 3034 | SDR 23.5 | 153 psi | Bell and Spigot |
| Sanitary Service | PVC | 4" and 6" | ASTM D 3034 | SDR 26 | 115 psi | Bell and Spigot |

Chapter 4 Watermains

4B-1 D. 2. a. Add the following statement:

The minimum size for service stubs is ¾-inch in diameter.

4B-1 D. 2. Add the following definitions:

d. Private Service Pipe: A water pipe installed, owned, operated, and maintained by the private consumer as further defined by current City Ordinances. Service pipes are often 1-inch diameter for residential and may be 2-inches to 6-inches in diameter for commercial or 8-inches to 12-inches in diameter for larger industrial applications.

e. Private Fire Hydrant: A fire hydrant which is located on privately owned property, or on streets not dedicated to public use unless the watermain is within a public easement. Private fire hydrants must be served by a minimum of a 6-inch diameter pipe. A private fire hydrant is the responsibility of the property owner and is to be for fire protection only. Where it is the owner intention that these hydrants be used by the City Fire Department, these hydrants shall conform to the City’s Design Standards. The City has the right to utilize the hydrants for flushing purposes.

4C-1 B. 4. Add the following sentence:

Watermains shall be constructed such that no services shall be extended beneath the paving of the circular turn-around of a cul-de-sac.

4C-1 D.1. Change the second sentence to read “300-feet” for both distances.

4C-1 E. 3. B. Change the first sentence to read “300-feet for both distances.

Change the third sentence of the second paragraph to read “300-feet” for both distances.

4C-1 E. 4. Add the following paragraph:

A fire hydrant shall be required at the end of all dead end lines. The locations of the fire hydrant may be modified at the request of the Jurisdictional Engineer or Fire Department.

4C-1 F. Add the following paragraphs and Table 4C-1.02:

No water consumer shall construct water service pipes across lots or buildings to adjoining premises, but all service pipes shall be laid within streets, alleys or public ground to the premises to be served, and enter at the front or rear of the building nearest the main. Such service pipe shall be laid in a straight line at right angles to the watermain within two lines extended from the sides of the building to be served, or not more than 3-feet outside of these lines. Service pipe must be either seamless annealed copper, Type K conforming to ASTM B-88, or Polyethylene 3408 as defined in current ASTM D 2239 and AWWA C-901, Polyethylene 200 psi rated pipe.

Service shut-off (curbstop) shall be located in or within 1-foot of the public right-of-way whenever possible. Curbstops shall not be within street, sidewalk, or driveway pavement whenever possible. Curbstops located outside of the right-of-way shall be located in an easement with ingress/egress rights for operation and maintenance of the service shut-off. Multiple stop boxes shall be permanently marked to identify the correct individual metered service.

Table 4C-1.02
WATER SERVICE CONNECTIONS ⁽¹⁾

| Type | Number of Connections and Size of Service Pipe | Number of Meters and Billing Requirements |
|-------------------------------------------------------|-------------------------------------------------------------------------------------------------------------------------------------------------------------|--------------------------------------------------------------------------------------------------------------------------------------|
| SINGLE FAMILY | 1 – 1” | 1 Meter – 1 Curb Stop Individual Billing |
| DUPLEX OR ZERO- LOT LINE | 2 – 1” | 1 Meter for Each Unit, 2 Curbstops Individual Billing |
| TOWNHOUSE OR MULTIPLE SIDE- BY-SIDE APARTMENTS. | 1 – 1” for each unit | All units must be plumbed for individual meters and curbstops. |
| MULTI-STORY APARTMENTS MAX. 6 UNITS | 1 – 1” for each unit | All units must be plumbed for individual meters and curbstops. |
| MULTI-STORY APARTEMENTS 7 UNITS OR MORE ^{*)} | Requires City Engineer Approval. Must be sized for available main pressures and line distances. May require larger private service built to City standards. | All units must be plumbed for individual meters. Apartments or condominiums with specific by-laws may have single meter and Billing. |
| COMMERCIAL OR MIXED USE DEVELOPMENT ^{**} | Requires City Engineer Approval. Must be sized for available main pressures and line distances. May Require larger private service built to City standards. | All units must be plumbed for individual meter. Commercial and residential users must have separate meters and billing. |

(1) All services shall be designed to accommodate available pressures in existing watermain, distances from the main to the user, and the City’s fire protection requirements.

^{*)} Apartment or condominiums with three habitable stories or any other structure with 9 or more dwelling units is required to provide a fire protection sprinkler system. This system must be designed in accordance with the City’s Building Code requirements, and be approved by the City Engineer.

4C-1 N Add the following section:

N. Location of Easements

1. All watermains shall be located within the public right-of-way. In rare exceptions, dedicated easements may be used for location of watermain outside of the right-of-way.

2. The minimum easement width is 10-feet.

Chapter 5 Roadway Design

5A-1 C. Add the following subsection

C. Permits

State and federal permits may be required, depending on the circumstances. It shall be the responsibility of the Project Engineer to acquire all applicable permits. A copy of the permits shall be provided to the City prior to construction.

5B-1 F. Add the following section:

F. Industrial Streets

Industrial streets are intended to carry industrial traffic and service as a means of access to abutting industrial property.

5B-1 G. Add the following section:

G. Cul-de-sacs

Cul-de-sacs are placed at the end of streets to provide turn-around capabilities.

5C-1 E. Add the following section

E. Other Jurisdictional Requirements

1. Minimum Criteria

In general, roadway elements shall conform to SUDAS Design Standards, however, Table 5C-1.06, Minimum Criteria for Roadway Elements, shall apply.

2. Signage

Developers shall pay the City the costs of all initial street signage for all new developments. The costs shall be determined on a unit cost per sign basis for the type and number of signs required as determined by the City Engineer and approved by Council action.

5C-2 J. Add the following paragraph:

Variations to clear zone requirements will be considered for overhead electric facilities where compliance will significantly impact existing trees. In no case will a clear zone of less than 18-inches be allowed. A clear zone variance must be approved by the City Engineer. Every effort shall be made to eliminate sight obstructions within the right of way.

5C-2 L. Add the following as the third sentence in the first paragraph:

A slope of 1/4 inch per foot or 2% is preferable within the City of Tiffin especially near intersections to better manage ADA compliance.

5C-2 L. Add the following paragraphs:

1. In residential areas, the parkway shall be grassed except in such areas that the parkway is so narrow the grass does not grow well. In these narrow areas, the alternate materials described in paragraph 2 may be used upon approval of the City Engineer.

2. In commercial areas, alternate materials shall be used in the parkway upon approval of the City Engineer. These materials include exposed aggregate concrete, asphalt and bricks, or concrete pavers on an asphalt or concrete base.

**Table 5C-1.06
Minimum Criteria for Roadway Elements**

| Design Standard | Arterial | Collector | Local | Industrial | Cul-de-sacs | | |
|-----------------------------------------------------------------------------------------------------------------------------------------------------------------------------------------------------------------------------------------------------------------------------------------------------|----------|----------------------|----------------------|------------|----------------------------------------|-------|------------|
| | | | | | Design Standard | Local | Industrial |
| Minimum right-of-way width (3) | 100' | 80' | 66' | 66' | | | |
| Minimum lane width | 12' | 12' | 12' | 12' | Minimum right-of-way radius | 67.5' | 75.0' |
| Auxiliary Lane | 12' | 12' | N/A | N/A | | | |
| Minimum pavement width (1)(4) | 36' | 36' | 31' | 34' | Minimum Bulb Paving Radius | 50' | 59' |
| Maximum grade | 8% | 10% | 10% | 8% | Maximum grade | 8% | 8% |
| Minimum grade | 0.5% | 0.5% | 0.5% | 0.5% | Minimum grade | 0.70% | 0.70% |
| Minimum pavement curve radius (5) | 1,000' | 350' | 150' | 150' | Minimum stem to bulb transition radius | 50' | 75' |
| Median Width (7) | 16' | 4' Paved 9' Grass | 4' Paved 9' Grass | | | | |
| Minimum pavement thickness (P.C.C.) (2) (6) | 9" | 8" | 7" | 8" | Minimum pavement thickness (P.C.C.)(2) | 7" | 8" |
| Minimum pavement thickness (A.C.C.) (2) (6) | 10" | 9" | 8" | 9" | Minimum pavement thickness (A.C.C.)(2) | 8" | 9" |
| (1) including curb and gutter | | | | | | | |
| (2) may have additional granular subgrade requirements depending on existing soils and anticipated traffic conditions | | | | | | | |
| (3) Additional width is required for medians or boulevards if they are planned within the right-of-way. This additional right-of-way shall be dedicated to the City by the Developer. | | | | | | | |
| (4) A larger pavement width may be specified for roadways defined as Prescribed Roadways" in the City of Tiffin Access Regulation Ordinance. | | | | | | | |
| (5) Under no circumstances will variances be granted for radii less than 75-feet. | | | | | | | |
| (6) Pavement thickness and subgrade requirements are intended as a guide. Street projects shall be designed on the basis of soil conditions and the projected traffic loadings. | | | | | | | |
| (7) Medians or boulevards which are included as a part of local or collector streets shall have a minimum width of 4-feet if paved of 9-feet if grassed. Paved medians on local and collector streets are discouraged, unless desired by the City at intersections. Raised medians are not allowed. | | | | | | | |

5I-3 C. 3. Add the following paragraphs

Access spacing shall be regulated by the City of Tiffin in the following manner:

A. Minor Arterial Roadways

The minimum distance between the centerlines of roadway access points shall be 300-feet. Driveways to individual lots abutting arterial roadways are prohibited unless the driveway provides access to/from a commercial or multi-family residential area with 18 or more dwelling units. A driveway access to these areas must be warranted by a traffic study and have concurrence by the Jurisdictional Engineer.

B. Collector Roadway

The minimum distance between centerlines of roadway access points shall be 125-feet. A maximum distance of 450-feet shall also be applied. A single driveway access will be allowed for each lot abutting a collector roadway. In the case of a corner lot, the driveway access must be to/from the street with the lower classification. One additional driveway access may be permitted if all of the following criteria are met.

1. The frontage length is greater than 150-feet.
2. The additional driveway is warranted by a traffic study.
3. Concurrence by the Jurisdictional Engineer.

Driveway access points should be coordinated to minimize turning conflicts.

C. Local Roadway

The minimum distance between the centerlines of roadway access points is 125-feet. A single driveway access shall be allowed for each lot abutting a local roadway. One additional driveway access may be permitted if the lot has frontage length greater than 150-feet. Concurrence of the Jurisdictional Engineer is required.

D. Industrial Roadway

The minimum distance between the centerlines of roadway access points is 125-feet. A single driveway access shall be allowed for each lot abutting an industrial roadway. Additional driveway access point may be permitted based on projected traffic and concurrence of the Jurisdictional Engineer.

5N-1 Add the following subchapter 5N-1:

5N-1 Alleys

A. Approvals and Permits,

1. Plans and specifications for public alley improvements must be reviewed and approved by the City Engineer prior to construction.

2. Local, state and federal permits may be required, depending on the circumstances. It shall be the responsibility of the Project Engineer to acquire all applicable permits. A copy of all permits shall be provided to the City prior to construction.

B. Alley Classification

1. A Residential Alley is a route located between local streets used primarily for access to the rear of residential property.

2. A Commercial Alley is a route located in commercial areas used primarily for access to the rear of commercial property.

C. Right-Of-Way Width

The right-of-way width shall be 20 feet for all alleys.

D. Pavement Width

1. Residential alleys shall have a minimum pavement width of 16 feet.

2. Commercial alleys shall have a minimum pavement width of 20 feet.

E. Alley Grades

The maximum grade for alleys shall be 8% for residential and 5% for commercial alleys. The minimum grade shall be 0.5% for all types of alleys.

F. Alley Pavement Cross Section

The pavement shall have a 4% inverted crown cross-section, or as approved by the City Engineer.

G. Pavement Material and Thickness

1. The pavement slab may be constructed of the following materials:
 - a. Non-reinforced Portland cement concrete conforming to the IDOT specifications C-3 mix or M-3 mix as applicable.

 - b. Full depth asphaltic concrete hot mix conforming to the IDOT specifications for Type “B” base and Type “A” surface course.

2. Minimum alley pavement thickness:

| | <u>Residential</u> | <u>Commercial</u> |
|--------------------------|--------------------|-------------------|
| Portland Cement Concrete | 6" | 7" |
| Asphalt Cement Concrete | 7" | 8" |

H. Subgrade Requirements

The subgrade shall have the same requirement as local streets.

50-1 Add the following subchapter 50-1:

50-1 Driveways, Entrances and Points of Access

A. Approvals and Permits

1. An access permit must be obtained before driveway construction or reconstruction work is done within the street right-of-way not associated with the construction of a new house or business for which a building permit has been obtained. However, the standards set forth in this document apply to all driveway construction. A sketch with dimensions shall be submitted showing the driveway in relation to intersections, side lot lines and other driveways.
2. A permit must be obtained from the Iowa Department of Transportation before placing or modifying a driveway within any state highway right-of-way.
3. Contractor must provide a Certificate of Insurance identifying the City as an "Additional Insured" party for the duration of the construction activity.

B. Traffic Control

1. The contractor doing the work is responsible for all traffic control and work site safety. If construction activities extend onto the street right-of-way, traffic control shall meet the standards for Work Zone Traffic Control defined in the current edition of the "Manual on Uniform Traffic Control Devices." Traffic control plans may be required.
2. The contractor shall provide adequate barricades and/or fencing to protect pedestrians continuously from the start of construction to the completion of work.

C. Driveway Material, Thickness and Finish

1. In Residential Zoning the driveway slab extending from the street to private property shall be constructed of Portland Cement Concrete conforming to the specifications of the Iowa Department of Transportation C-3 or M-3 mixes. The concrete driveway slab shall be a minimum of 6-inches thick.
2. All proposed Commercial or Industrial driveways must be hard surfaced from the street to the property line. Other driveway surfaces (ACC, seal coat, or special materials) may be approved, upon application to the City Engineer, contingent upon satisfactory compliance of all other requirements of this section, and any other conditions required by the City.

D. New and Replacement Culverts

1. New driveways constructed on streets without curb and gutter shall have culverts as approved by the City. Replacement of existing culverts must be approved by the City.
2. A written request for installation of a new or replacement culvert must be submitted to the City, and must be accompanied by a drawing that shows:
 - a. culvert dimensions, length, diameter, and culvert material
 - b. culvert location in relationship to property lines, street centerline and utilities
 - c. All culvert installations shall be reviewed and approved by the City Engineer.

d. All culverts must have a minimum diameter of 12-inches. All culverts must be constructed of either 2000D strength reinforced concrete pipe (RCP) or 10 gauge corrugated metal pipe (CMP).

3. Culverts are the responsibility of the property owner. The City accepts no responsibility for maintenance, repair, replacement, or procurement of contractors. Failure to install culverts in accordance with City requirements will result in removal and replacement at property owner's expense.

E. Curb Removal and Joint at Pavement

Curb drops shall be constructed as detailed in Figure 7030.102 of SUDAS Standard Specifications.

F. General Conditions for All Classifications of Driveways

The maximum driveway widths are listed in Table 50-1.01. On lots with multiple frontages the major driveway shall be on the lower classified street. Some subdivisions may prohibit access onto the higher classification street. Check the subdivider's agreement and the City of Tiffin Access Regulation Ordinance in each case. The following minimum driveway separations will also apply.

1. There shall be a minimum of twenty (20) feet between the end of a radius of a street intersection and the beginning of a driveway curb cut as measured at the curb line in all instances. Additional distance between the radius of a street intersection and the beginning of a driveway curb cut may be required by the City Engineer where deemed necessary because of high traffic volumes or other safety concerns.

2. A six (6) foot minimum distance between curb cuts of adjacent entrances at the curb line will be required.

3. The curb return shall not be constructed closer than three (3) feet to the side property line extended.

**Table 50-1.01
Maximum Driveway Widths (6)**

| Zoning District | Frontage Type | Driveway Width | | Number Allowed | In | Lanes and Medians | | |
|--------------------------------|--------------------------|----------------|--------|----------------|-----|-------------------|-----------|---------------|
| | | @ Sidewalk | @ Curb | | | Out Left | Out Right | Median Note 2 |
| Single Family | Single | 24' | 30' | 1 | | | | |
| | Single | 12' | 18' | 2 max. | | | | |
| | Shared | 30' | 36' | 1 | | | | |
| | Double (1) | 24' | 30' | 1 | | | | |
| | | and | | | | | | |
| | | 12' | 18' | 1 | | | | |
| Two Family | Separate | 24' | 30' | 1/unit | | | | |
| | Common | 30' | 36' | 1 | | | | |
| All other Residential | Single | 34' | 42' | 1/ Lot | | | | |
| | Single | 24' | 32' | 2/Lot max. | | | | |
| | >150 feet | 34' | 42' | 2/Lot | | | | |
| | Double | 34' | 42' | 3 max. | | | | |
| Non-Residential and Industrial | Driveway Type (4) | | | | | | | |
| (Shared Driveway) | "A" | 45' | (3) | 1 | 16' | 12' | 12' | 4' |
| (Shared Driveway) | "B" | 41' | (3) | 1 | 16' | 12' | 12' | |
| Single Driveway | "C" | 28' | (3) | 1 | 14 | 1-14' lane out | | |
| State Highway | | (5) | | | | | | |

- (1) For corner lot, major Driveway is required to be on the lower classified roadway.
- (2) Median may be painted or raised with curb.
- (3) Special design, radius returns may be required.
- (4) Driveway Type generally follows IDOT Iowa Primary Highway Access Management Policy.
- (5) Entrance design governed by IDOT Iowa Primary Highway Access Management Policy.
- (6) Distances may be varied by the City Engineer in certain instances in the existing developed areas of the City, as necessary.

G. Driveway Grades

Figure 5O-1.07 shows a typical roadway cross-section at an entrance.

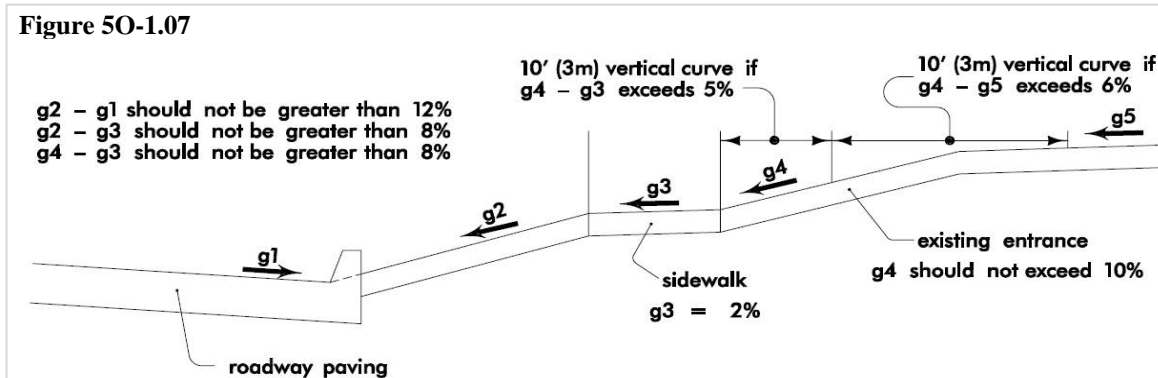
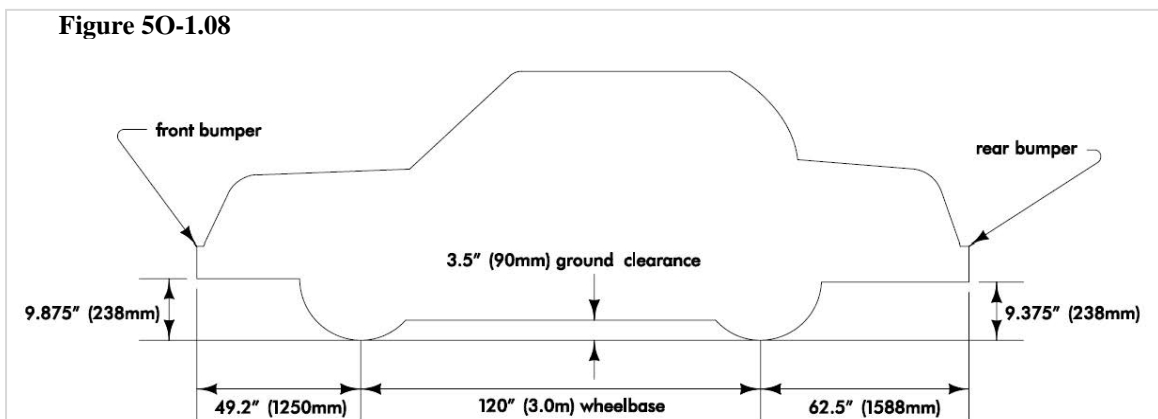

Figure 5M-1.08 shows a typical design vehicle for driveway design.

The information in this paragraph should be used as a guide for driveway design. In all cases, Figure 7030.103 of the SUDAS Standard Specification shall apply. The entrance profile (g_2) should slope upward (positive grade) from the gutter line to the curb side of the sidewalk (if present) with a maximum algebraic difference of 15% between the cross slope of the traveled way (g_1) and the positive slope of the driveway (g_2). Vertical curves should be used if $g_4 - g_3$ exceeds 5% or if $g_4 - g_5$ exceeds 5%. The designer should check the entrance profile with a template similar to Figure 5L-1.08 to ensure ample vertical clearance between the driveway surface and the underside of the design vehicle in the maximum range. The designer should also consider any special vehicles that may use the entrance, such as limousines or campers, to ensure ample vertical clearances exist for these vehicles.



All entrances in urban settings should be paved to prevent aggregate from washing onto the pavement, curb, and gutters. If the existing drive is not paved, pave the first 10 feet from the back of curb or to the edge of the existing sidewalk.

All entrances should be constructed so as not to impair drainage within the highway right-of-way nor alter the stability of the highway subgrade and at the same time not impair or materially alter drainage

of the adjacent areas. All culverts, catch basins, drainage channels, and other drainage structures required under driveways as the result of property being developed should be installed in accordance with current standards and specifications.

Chapter 6 Geotechnical

6E-1 G. Add the following subsection:

J. Other Jurisdictional Requirements

All roadways, streets, alleys shall be designed with engineered subgrade. As a minimum, the top 6-inches of the subgrade shall be scarified and re-compacted to 95% standard proctor density. Additional compaction may be required based on soil conditions and expected traffic volumes. Soil amendment may also be required.

6F-1 J. Add the following subsection:

J. Other Jurisdictional Requirements

All paved roadways, streets, alleys and driveways shall be designed with either Granular Subbase (IDOT Gradations 12) or Modified Subbase (IDOT Gradation14) with a minimum thickness of 6-inches. Additional thickness may be required based on soil conditions and expected traffic volumes.

6G-1 H. Add the following subsection:

H. Other Jurisdictional Requirements

All roadways, streets, and alleys shall be designed with subsurface drainage systems.

Chapter 7 Erosion and Sediment Control No amendments

Chapter 8 Parking Lots

8C-1 G. Add the following subsection:

G. Other Jurisdictional Requirements

The installation of all parking shall comply with the standards described herein as well as the requirements of the Zoning Ordinance. All required parking shall be provided on private property. On-street parking may not be counted for meeting the parking requirements listed in the Zoning Ordinance.

These standards are intended to serve as a supplement to the regulations located in the City of Tiffin Zoning Ordinance. The Zoning Ordinance regulations include, but are not limited to, provisions for: the required number of parking spaces for a particular use, the parking of recreational vehicles, and the use of off-street parking. The City of Tiffin Zoning Ordinance should be consulted in conjunction with these Design Standards.

1. Required Landscaping for Off-Street Parking

All off-street parking areas for multiple-unit residential and commercial projects shall receive landscaping, both around their perimeter and within the interior of the parking lot, according to the following standards.

2. Landscaping Requirements

All required front setback areas shall be landscaped except for driveways. All parking spaces and back-up areas, except for driveway parking for single-family dwellings, shall be located behind the required front yard setback.

All parking areas shall provide a minimum five-foot landscape planting area around the perimeter of the parking, except for driveway access. Landscape planting areas shall be widened to accommodate vehicle overhand, resulting in 8'-0" width adjacent to standard spaces. Only low

level shrubs and groundcover shall be used in vehicle overhang areas. Perimeter landscaping shall be used to screen the parking lot from the public view by the use of shrubs and/or decorative mounding to an effective height of 3.5 feet and shall utilize street trees at the ratio of 1 tree per 40 feet of street frontage.

All interior landscaping planting areas shall provide trees selected to provide shade canopies with a minimum diameter of ten feet at maturity.

The amount of required interior parking lot landscaping may be reduced by the Planning and Zoning Commission when the following findings are made:

- a. It effectively mitigates the visual impact of a broad expanse of pavement through careful placement of trees and other vertical elements such as vines and landscaped banks.
- b. It helps promote safe traffic circulation.
- c. It is provided in an area large enough to ensure its survival.

All landscaping (perimeter and interior) shall be separated from the parking pavement by a continuous 6-inch Portland cement concrete curb.

3. Security Lighting

Lighting shall be provided in all parking areas to provide an adequate level of security.

All lighting shall be screened so that it does not illuminate adjacent properties. In general, light bulbs should not be directly visible from any adjoining residential property.

Chapter 9 Utilities

9D-1 E. Add the following subsection E:

E. Other Jurisdictional Requirements

1. Work Around Trees
 - a. Use care to prevent work within the drip line of trees.
 - b. When work falls within the drip line of trees, contact the City Hall.
2. Restoration of Pavement Surface
Follow SUDAS Section 7040.

3. Other Surfaces

All areas outside the pavement which are disturbed shall be restored to their original condition.

When approved by the governing authority, unimproved streets (rock or rock and oil, seal coated streets) may be repaired or restored with Bituminous Seal Coat consisting of one or more applications of Binder Bitumen with one or more successive applications of cover aggregate. Materials, Equipment and Construction methods shall be in general conformity with Section 2307 of the current Iowa Department of Transportation Standard Specifications for Highway and Bridge Construction.

Chapter 10 Street Tree Criteria No amendments

Chapter 11 Street Lighting

11C-1 D. Add the following subsection D:

D. Other Jurisdictional Requirements

1. Light Fixture Spacing

At a minimum, light fixtures shall be placed at intersection and at mid-block. Additional fixtures are required at intervals that allow for continuous lighting along the sidewalks of the block.

Contact City Hall for a list of approved lighting fixtures.

Chapter 12 Sidewalks and Bicycle Facilities

12A-1 E. Add the following subsection E:

E. Other Jurisdictional Requirements

1. Width and Location

a. Sidewalk and trail widths shall be a function of Street Classification (see Section 5 for definitions of road designations), expected use, and Zoning.

b. Sidewalks in the public right-of-way shall be located 1-foot from the property line, except in areas in which a different offset is required to match existing walks or where topographical constraints exist.

c. Sidewalks that extend to the street perpendicular to the curb shall only be located at intersections, cluster mailbox locations, and designated mid-block crossings. Such perpendicular sidewalks in other locations removed for construction or maintenance activities shall not be replaced.

d. Sidewalks are required on both sides of all streets, except in Industrial Zoning.

2. Matching Existing Walks

a. The width and location of a new sidewalk shall match the width and location of existing sidewalks in the area. However, the sidewalk width shall not be less than 5 feet (no tapers allowed).

b. Sidewalk cross slope may be varied through a gradual transition to match existing adjoining walks. Contact City Hall if existing adjoining walks vary significantly from existing standards.

Chapter 13 Traffic Signals No amendments

Chapter 14 Trenchless Construction No amendments

Chapter 15 Miscellaneous No amendments

Chapter 16 Fencing Add the following as Chapter 16 Fencing:

16A-1 A. Fencing Requirements

1. At the time of approval of the final plat, the Subdivider of any subdivision which has a boundary abutting land used for agricultural purposes shall agree to be responsible for the construction and maintenance of all fences between the subdivision and all land used for agricultural purposes. A required fence shall consist of either:

a. Not less than 26 inches of substantial woven wire on the bottom with three strands of barbed wire with not less than 36 barbs of at least 2 points to the rod on top; the top wire to be not less than 48 inches, nor more than 54 inches high; or

b. Good substantial woven wire of not less than 48 inches nor more than 54 inches high, with one barbed wire of not less than 36 barbs of 2 points to the rod, nor more than four inches above said woven wire.

These fence construction standards shall be considered the minimum standard to be required by agreements pursuant to this article.

2. The Subdivider shall satisfy the following conditions regarding fences:

a. At the time of submittal of the final plat, the Subdivider shall submit a Subdivider's Agreement with the City that sets forth provisions for fence agreements with the owners of property adjoining the land included in the final plat. The fence agreement will specify the responsible party of fence construction and maintenance.

b. Required fence agreements shall at a minimum, contain the following:

1.) A statement that the agreement shall be binding on both parties, their heirs, and assigns.

2.) A statement that the agreement shall run with the land.

3.) A termination clause effective upon the subdivision of the adjoining property for non-agricultural purposes.

3. Prior to approval of the final plat, the subdivider shall submit copies of the recorded fence agreements with the owners of property adjoining the final plat. Where the owner of property adjoining the plat shall fail to enter into said fence agreement the City of Tiffin may nevertheless approve the final plat after the following condition has been satisfied:

a. The Subdivider's Agreement with the City states that the Subdivider is the sole responsible party for fence construction and maintenance for all fences abutting land used for agricultural purposes.

The Statewide Urban Design and Specifications (SUDAS) Standard Specifications Manual shall be adopted with the following amendments:

Division 1 – General Provisions and Covenants

Section 1020 – Proposal Requirements and Conditions

Article 1.09 A. Add the following subparagraphs paragraphs 1-3

1. Proposals shall be prepared on the exact colored copy of the “Form of Proposal” included in these specifications as provided by the Engineer. All applicable blank spaces shall be filled in, typewritten or in ink. If unit price and extension are in conflict, unit price shall govern. All boxes shall have numbers in the unit or it shall be considered a zero bid.

2. Proposals shall indicate the full name of Bidder, shall be signed in the firm or corporate name of the bidder, and shall bear the longhand signature of a principal duly authorized to execute contracts for the bidder. Proposals signed by an agent of the bidder must be accompanied by evidence of the agent’s authority to execute contracts for the bidder. The name of each person signing the proposal shall be typed or printed below the signature.

3. All erasures or corrections shall be initialed by the person signing the proposal.

Article 1.15 A. Change sentence to read “90 calendar days.”

Section 1030 Approval for Award and Award of Contract

Article 1.03 B. Add the following subparagraphs 1-2

1. Targeted Small Business (TSB) Contract Provisions (if applicable)

2. State Revolving Fund (SRF) Requires Front-End Specifications (if applicable)

Section 1070 Legal Relations and Responsibility to the Public

Article 3.01 B. Add the following as the second paragraph

The duration of the bond shall be three (3) years.

Article 3.02 C. 6. The Engineer shall also be listed as an additional insured

Article 3.05 M. The “Installation Floater” is not required for grading and paving portions of the contract.

Division 4 - Sewers and Drains

Section 4010 Sanitary Sewers

Article 1.08 A. 1. c. Make the following change

1.08. A.1.c. Sanitary Service Wyes will be paid as a separate item. Each type and size of wye installed as specified in the contract documents will be counted. Payment will be made at the unit price for each type and size of wye. Unit price includes but is not limited to all equipment, labor, and materials necessary to install sanitary service wye in accordance with the Plans and Specifications. Cleaning, Inspection and Testing will be paid as a separate item. See Section 4060.

Section 4060 Cleaning, Inspection and Testing of Sewers

Article 1.08 Make the following change

1.08 Measurement and Payment

Cleaning, Visual Inspection, Low Pressure Air Testing, and Deflection Testing will be required. Inspection and Testing will be paid at the unit bid price. Video inspection may be required, at the direction of the Engineer, if other testing fails. Costs associated with video inspection shall be incidental to the Cleaning, Inspection, and Acceptance Testing item.

Division 5 – Water mains and Appurtenances

Section 5010 Water mains and Appurtenances

Article 1.08 C Make the following changes to Article 1.08 C

1.08 C. 1.a. Measurement

Each Fitting(tee, bend, reducer, sleeve, cap, etc.) installed as specified on the plans, Contract Documents, or as required for proper installation of the water main will be counted regardless of size.

1.08 C. 1. b. Payment

Payment will be made at the contract unit price for each fitting installed.

Article 2.03 Add the following statement

Preferences will be made for domestically made products and materials.

Article 2.07 C Add the following Jurisdictional Requirements

2.07 C. Corporations, Stops, and Stop Boxes

Corpstop shall be A.Y. McDonald #4701, #4701B, or approved equal.

Curbstops shall be A.Y. McDonald #6100, or approved equal.

Stop boxes shall be A.Y. MCDONALD #5607L with stainless steel operating rod, or approved equal. Stop box cap shall have removable brass access plug.

Preferences will be made for domestically made products and materials.

Article 3.06 H. Add the following Jurisdictional Requirements

H. The above tracer wire system requirements shall also apply to water service piping. Tracer wire shall be installed with the service piping from the water main to the building that is being served.

Tracer ware shall be tied into the tracer wire system of the watermain.

Section 5020 Valves, Fire Hydrants, and Appurtenances

Article 1.08 Make the following changes

1.08 A. Valve (Butterfly or Gate)

1.08 A.3 Includes:

Unit price also includes furnishing all labor, materials, and equipment necessary to install Valves Box Adaptor II, manufactured by Adaptor Inc., or approved equal, with all proposed valve boxes.

1.08 B. Tapping Valve Assembly

1.08 B.3 Includes:

Unit price also includes furnishing all labor, materials, and equipment necessary to install Valves Box Adaptor II, manufactured by Adaptor Inc., or approved equal, with the valve box.

1.08 C. Fire Hydrant Assembly

1.08 C.3 Includes:

Unit price also includes furnishing all labor, materials, and equipment necessary to install Valves Box Adaptor II, manufactured by Adaptor Inc., or approved equal, with the valve box.

1.08 G. Valve Box Replacement

1.08 G.3 Includes:

Unit price also includes furnishing all labor, materials, and equipment necessary to install Valves Box Adaptor II, manufactured by Adaptor Inc., or approved equal, with all replaced valve boxes.

Article 2.01 B. 4. Add the following article

4. Gate Valves shall be American Flow Control Series 2500, Clow Figure F6100, Mueller Series 2360, or approved equal. Preferences will be made for domestically made products and materials. All valves shall be resilient wedge gate valves with mechanical joints, 2-inch square operating nut, open counter-clockwise, and 3-foot stem extensions.

Article 2.02 C. 6. a. - d. Substitute the following for the specified items

- a. 1 ½-inch pentagon operating nut, open counter-clockwise.
- b. 5-inch integrated Storz hose coupling pumper nozzle.
- c. Nozzles shall have National Standard Hose threads.
- d. 5 ¼-inch main valve opening.

Article 2.02 C. 7. Add following Article

7. Proposed hydrants shall be 5 ¼-inch Waterous Pacer (WB67), Clow Medallion, or approved equal and painted Silver in color with Red caps. Preferences will be made for domestically made products and materials.

Hydrants shall be oriented such that the pumper nozzle faces the street, or if at intersection, faces the higher classification street.

Article 2.03 Add the following as 2.03 D.

2.03 D. Valve Box Adaptor

Valve Box Adaptor II, manufactured by Adaptor Inc., or approved equal, shall be installed between the valve body and valve box per manufacturer's recommendations.

Section 5030 Testing and Disinfection

Article 1.08 Make the following change

1.08 Measurement and Payment

Testing and disinfection of water mains will be paid at the Lump Sum unit price established by the Contract.

Division 6 – Structures for Sanitary and Storm Sewers

Section 6010 Structures for Sanitary and Storm Sewers

Article 1.08 A. 3. Make the following change

1.08. A.3. Each type of Chimney Seal will be counted by the Engineer. Payment will be at the unit bid price for each type of Chimney Seal installed. Unit price includes but is not limited to furnishing all equipment labor and materials necessary to install the type of Chimney Seal per manufacturer's recommendations and as shown on the Plans.

Add figure 6010.308

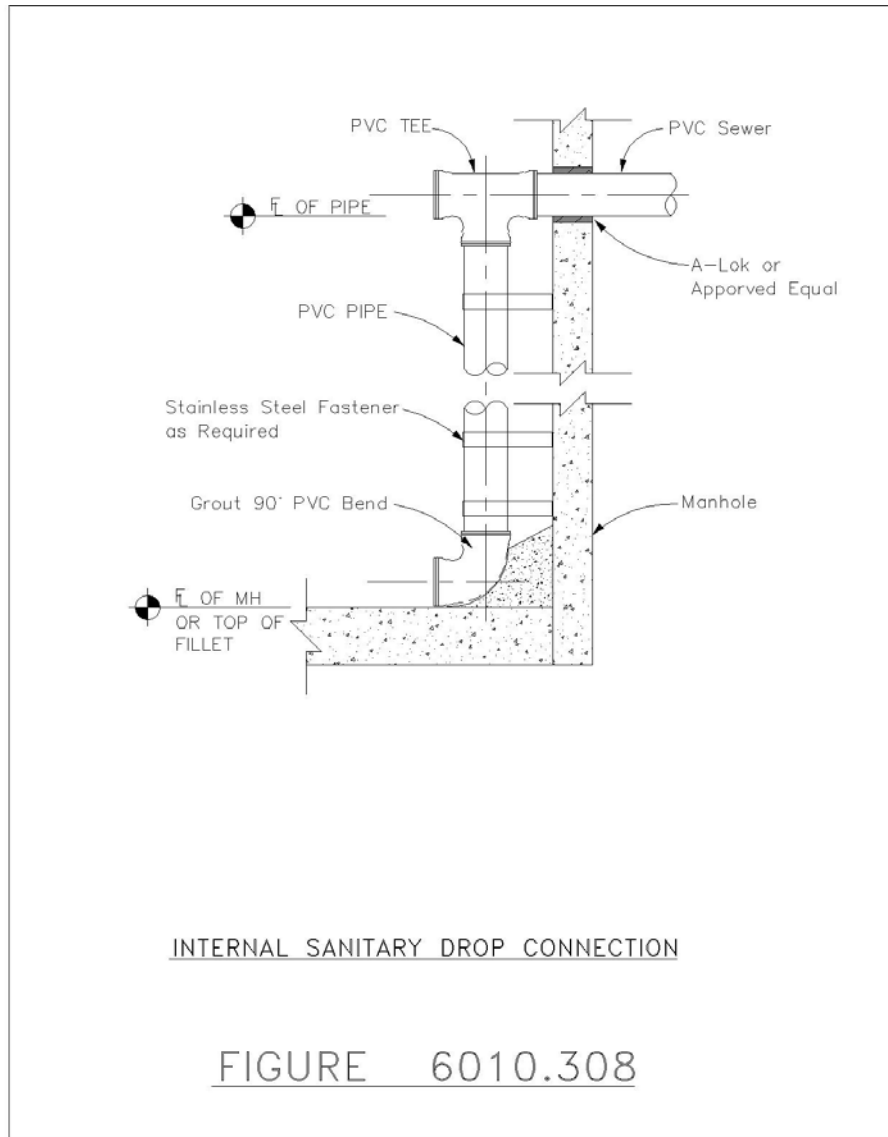

Division 7 – Streets and Related Work

Section 7030 Sidewalks, Shared Use Paths, and Driveways

Article 1.08 A. 1. Make the following change

1.08. A.1. Measurement:

Measurement will be in square yards. No Deduction in area will be made for manholes, storm sewer intakes, valve boxes, or other structures less the 2 square yards in area. The maximum payable trench width for trenched utility work shall be computed based on pipe diameter and depth of cut. Refer to Table 3-3 for maximum payable trench widths. Pavement removal outside of the maximum trench width will not be measured for payment unless directed by the Engineer. Pavement removal for patching is included as part of the patching item and will not be measured separately.

Section 7040 Pavement Rehabilitation

Article 1.08 H. 1. Make the following change

1.08. H.1. Measurement:

Measurement will be in square yards. No Deduction in area will be made for manholes, storm sewer intakes, valve boxes, or other structures less the 2 square yards in area. The maximum payable trench width for trenched utility work shall be computed based on pipe diameter and depth of cut. Refer to Table 3-3 for maximum payable trench widths. Pavement removal outside of the maximum trench width will not be measured for payment unless directed by the Engineer. Pavement removal for patching is included as part of the patching item and will not be measured separately.

The Statewide Urban Design and Specifications (SUDAS) Standard Specifications Manual shall be adopted with the following additions:

Traffic Control: Complete; Lump Sum (LS):

The Contractor shall accommodate and maintain access to all residential and commercial properties, unless approved by Engineer and Property Owner/Residents when not practical to do such until the construction activity has been completed. All traffic control shall be in accordance with the Iowa Department of Transportation Standard Specifications for Highway and Bridge Construction, Series 2015 (current revision) and the Manual on Uniform Traffic Control Devices (MUTCD). The contractor shall erect and maintain construction and warning signage, barricades, fencing, and delineating devices to ensure the safety of the traveling public through and around the jobsite. Contractor shall cover all permanent signage that is in conflict with or displays information that is contradictory to the construction signage. Unit price includes but is not limited to furnishing all labor, materials and equipment necessary to furnish, install, erect, maintain, move, and remove construction and warning signage, in accordance with the Plans, of Iowa Department of Transportation Standard Specifications for Highway and Bridge Construction, Series 2012 (current revision) and MUTCD, assuring safe traffic flow.

Light Poles, Electrical Circuits, Handholes & Junction Boxes (Highway Lighting)

In general Light Poles, Electrical Circuits, Handholes and Junction Boxes shall be in accordance with Section 2523 of Iowa Department of Transportation Standard Specifications for Highway and Bridge Construction, Series 2015 (current revision).

All materials shall meet the City Design Standards.

Light poles shall consist of a wooden pole of sufficient length such that the mounting of the luminaire is not less than 26 feet or more than 30 feet above the roadway surface.

Mast arm shall be galvanized steel.

Lighting fixture shall contain an LED light source with a minimum of 8,500 lumens (ASA, Type III) and shall meet Illumination Engineering Society (IES) Type II “sharp cutoff” lighting criteria (limited “fugitive light” and direct downward illumination).

TABLE 3-3 SURFACE REPLACEMENT QUANTITIES
PAY WIDTH LIMIT IN FEET AT TOP OF TRENCH SECTION FOR
SURFACE REPLACEMENT QUANTITIES PER LINEAL FOOT

| | | CUT IN FEET TO INVERT | | | | | | | | | | | | | |
|---------------|-------|-----------------------|------|------|------|-------|-------|-------|-------|-------|-------|-------|----|----|--|
| PIPE DIAMETER | SEWER | 4 | 5 | 6 | 7 | 8 | 9 | 10 | 11 | 12 | 13 | 14 | 15 | 16 | |
| 4" & 6" | 4" | 6.62 | 7.62 | 8.62 | 9.62 | 10.62 | 11.62 | 12.62 | 13.62 | 14.62 | 15.62 | 16.62 | | | |
| | 6" | 6.44 | 7.44 | 8.44 | 9.44 | 10.44 | 11.44 | 12.44 | 13.44 | 14.44 | 15.44 | 16.44 | | | |
| | 8" | 6.59 | 7.59 | 8.59 | 9.59 | 10.59 | 11.59 | 12.59 | 13.59 | 14.59 | 15.59 | 16.59 | | | |
| | 10" | 6.42 | 7.42 | 8.42 | 9.42 | 10.42 | 11.42 | 12.42 | 13.42 | 14.42 | 15.42 | 16.42 | | | |
| | 12" | 6.40 | 7.40 | 8.40 | 9.40 | 10.40 | 11.40 | 12.40 | 13.40 | 14.40 | 15.40 | 16.40 | | | |
| | 15" | 6.38 | 7.38 | 8.38 | 9.38 | 10.38 | 11.38 | 12.38 | 13.38 | 14.38 | 15.38 | 16.38 | | | |
| | 18" | 6.34 | 7.34 | 8.34 | 9.34 | 10.34 | 11.34 | 12.34 | 13.34 | 14.34 | 15.34 | 16.34 | | | |

| | | CUT IN FEET TO INVERT | | | | | | | | | | | | | |
|---------------|-----------|-----------------------|-------|-------|-------|-------|-------|-------|-------|-------|-------|-------|----|----|--|
| PIPE DIAMETER | SEWER | 15 | 16 | 17 | 18 | 19 | 20 | 21 | 22 | 23 | 24 | 25 | 26 | 27 | |
| 4" & 6" | 4" | 17.62 | 18.62 | 19.62 | 20.62 | 21.62 | 22.62 | 23.62 | 24.62 | 25.62 | 26.62 | 27.62 | | | |
| | 6" | 17.44 | 18.44 | 19.44 | 20.44 | 21.44 | 22.44 | 23.44 | 24.44 | 25.44 | 26.44 | 27.44 | | | |
| | 8" | 17.59 | 18.59 | 19.59 | 20.59 | 21.59 | 22.59 | 23.59 | 24.59 | 25.59 | 26.59 | 27.59 | | | |
| | 10" | 17.50 | 18.50 | 19.50 | 20.50 | 21.50 | 22.05 | 23.50 | 24.50 | 25.50 | 26.60 | 27.50 | | | |
| | 14" | 17.50 | 18.50 | 19.50 | 20.50 | 21.50 | 22.50 | 23.50 | 24.50 | 25.50 | 26.50 | 27.50 | | | |
| | 16" & 18" | 17.50 | 18.50 | 19.50 | 20.50 | 21.50 | 22.50 | 23.50 | 24.50 | 25.50 | 26.50 | 27.50 | | | |
| | 20" | 17.50 | 18.50 | 19.50 | 20.50 | 21.50 | 22.50 | 23.50 | 24.50 | 25.50 | 26.50 | 27.50 | | | |